



**TECHNICAL SPECIFICATION**

**INPUT SPECIFICATION :**

Current	
Input Current	Through external shunt (-75mV To+75mV DC)
Shunt Selectable	5 to 9999 Amp
Voltage	
Direct voltage DC	0 to 1000V DC

**CALCULATED PARAMETERS :**

Parameter	Range	Accuracy
DC Voltage	0.00 - 49.99 V DC	1 % OF 49.99V
	50.0 - 199.9 V DC	1 % OF 199.9V
	200.0 - 399.9 V DC	1 % OF 399.9V
	400.0 - 1000 V DC	1 % OF 1000 V
DC Current	-999 - 9999 A DC	1 % OF FSD
WATT	-999 - 9999 KW	
KWH	0 - 999999 KWH	

**DISPLAY & KEYS :**

Display	6 Digit, 7 seg. 0.40" RED 4 Digit, 3 Line 7 seg. 0.40" RED
Key	RESET, PRG, INC, DEC

**DIMENSION :**

Size (mm)	96 (H) x 96 (W) x 54 (D) mm
Panel Cutout	92 (H) x 92 (W) mm

**AUXILIARY POWER SUPPLY :**

Power Supply	100V to 270V AC
Burden	Approx 5VA @ 230V AC

**ACCURACY**

Class 1.0 (Standard)

**ENVIRONMENTAL CONDITION**

Working Temperature	0 to 55 °C
Storage Temperature	0 to 55 °C
Relative Humidity	95 % RH Non-Condensing
Protection Level (As per Request)	IP-65 (Front side As per IS/IEC 60529 : 2001)

**MECHANICAL INSTALLATION**

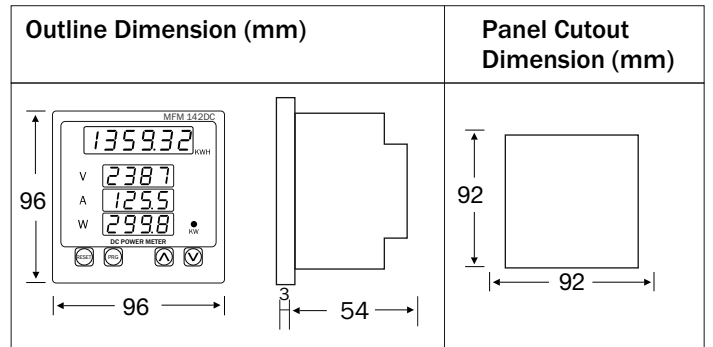

**TERMINAL CONNECTION**

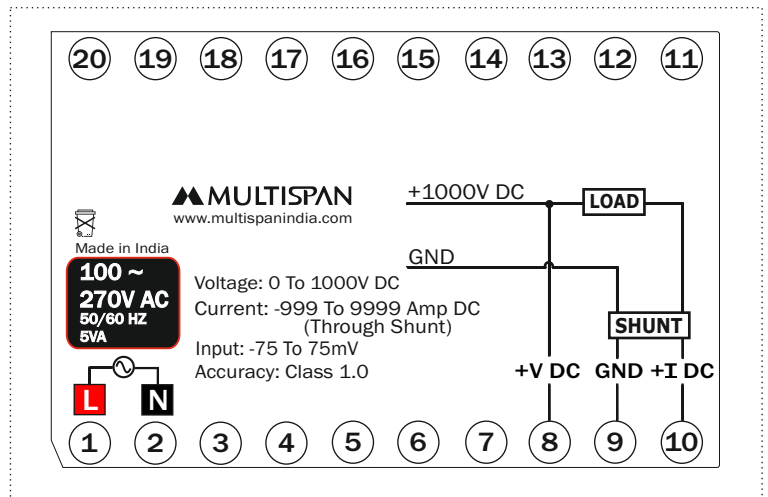

## DISPLAY INDICATION

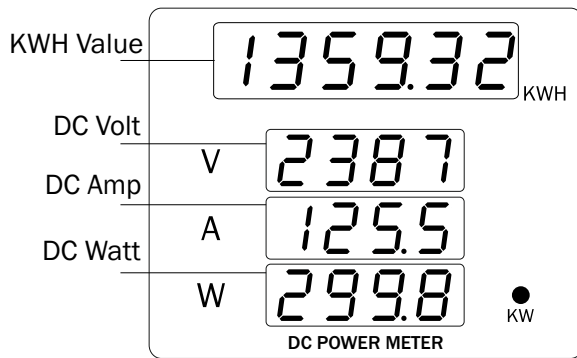

## KEY OPERATION

FUNCTION	PRESS KEY
<b>OPERATOR MODE</b>	
To enter in parameter setting	Press 5 sec
To Reset the KWH Value	
<b>PARAMETER SETTING MODE</b>	
To set parameter value	
To increment parameter value.	
To decrement parameter value.	
Set parameter to be save & exit.	

## MECHANICAL INSTALLATION

1. Prepare the panel cutout with proper dimensions as shown above.
2. Fit the unit into the panel with the help of clamp given.
3. The equipment in its installed state must not come in close proximity to any heating source, caustic vapors, oil steam, or other unwanted process byproducts.
4. Use the specified size of crimp terminal (M3.5 screws) to wire the terminal block. Tightening the screws on the terminal block using the tightening torque of the range of 1.2 N.m.
5. Do not connect anything to unused terminals.

## MAINTENANCE

1. The equipment should be cleaned regularly to avoid blockage of ventilating parts.
2. Clean the equipment with a clean soft cloth. Do not use isopropyl alcohol or any other cleaning agent.
3. Fusible resistor must not be replaced by operator.



## SAFETY PRECAUTION

Please read the "Safety Warnings" in the instruction manual supplied with the instrument thoroughly and completely for correct use. Failure to follow the safety rules can cause fire, trouble, electrical shock, etc. Therefore, make sure to operate the instrument on a correct power supply and voltage rating marked on each instrument.

If all the equipment is not handled in a manner specified by the manufacturer, it might impair the protection provided by the equipment.



Read complete instructions prior to installation and operation of the unit.



**WARNING** : Risk of electric shock.

## WARNING GUIDELINES



**WARNING** : Risk of electric shock.

- 1) To prevent the risk of electric shock, power supply to the equipment must be kept OFF while doing the wiring arrangement. Do not touch the terminals while power is being supplied.
- 2) To reduce electro magnetic interference, use wire with adequate rating and twists of the same of equal size shall be made with shortest connection.
3. Cable used for connection to power source, must have a cross section of 1mm or greater. These wires should have insulations capacity made of at least 1.5kV.
- 4) A better anti-noise effect can be expected by using standard power supply cable for the instrument.

## INSTALLATION GUIDELINES

- 1) Do not allow pieces of metal, wire clippings, or fine metallic fillings from installation to enter the product or else it may lead to a safety hazard that may in turn endanger life or cause electrical shock to the operator.
- 2) Circuit breaker or mains switch must be installed between power source and supply terminal to facilitate power 'ON' or 'OFF' function. However this mains switch or circuit breaker must be installed at convenient place normally accessible to the operator.
- 3) Use and store the instrument within the specified ambient temperature and humidity ranges as mentioned in this manual.

## PARAMETER SETTING

Press  Key For 5 Sec.  
To Enter in Parameter Setting

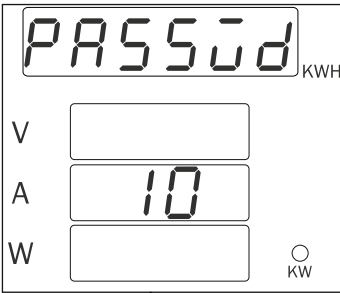

Password -  
(10)

Press  Key

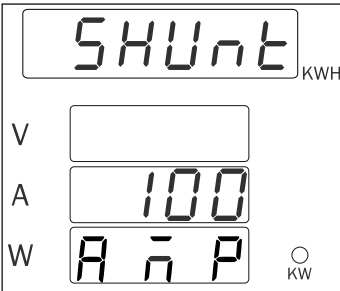

Shunt Selectable  
Range:  
5 to 9999Amp

Press  Key to Save & Exit

## KWH RESET

To Reset KWH Press  Key For 5 Sec

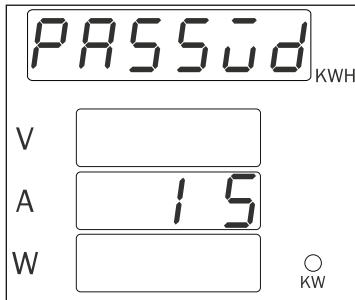

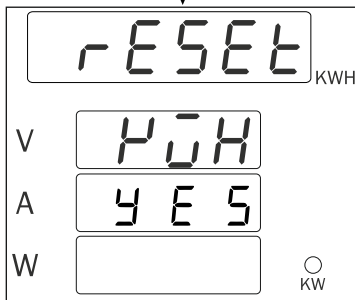

Password  
(15)

Press  Key



KWH  
YES/NO

To Reset KWH Press  Key

Note :- To Change Parameter Value  
Press  OR  Key