



FEATURE

- Earth Leakage Current Monitoring In 1Ø - 2W, 3Ø-3W And 3Ø-4W System
- Test Mode Available.
- Manual Tripping Reset Facility.
- Test/Trip Reset Via Front Key / Remote

TECHNICAL SPECIFICATION

INPUT SPECIFICATION :

Input Current	30mA To 30A AC From CBCT
Set Current Range	0.03A To 30Amp
Trip Delay Time	0 to 10 Second

KEYS :

Keys	Test , Rst
-------------	------------

OUTPUT SPECIFICATION :

Relay	1 Nos.
Relay Type	NO - C - NC
Rating	5A,230V AC Resistive Load

AUXILIARY SUPPLY :

Supply Voltage	100 To 270 V AC
Power Consumption (VA Rating)	2VA @ 230 VAC MAX

ENVIRONMENT CONDITION :

Operating Temp.	0 - 55°C
Relative Humidity	95% RH

MECHANICAL DIMENSION

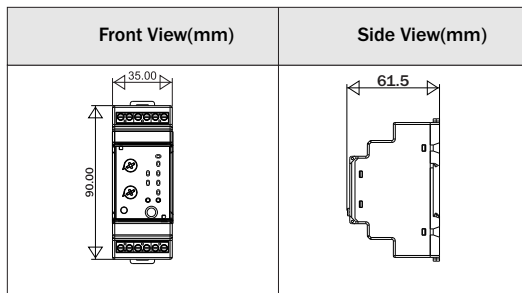

SIDE VIEW

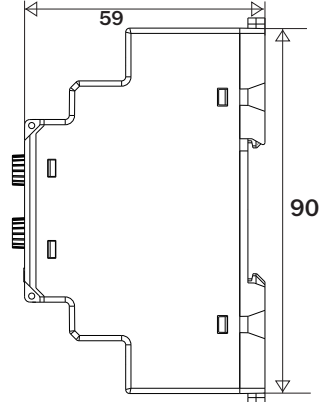

TERMINAL CONNECTION

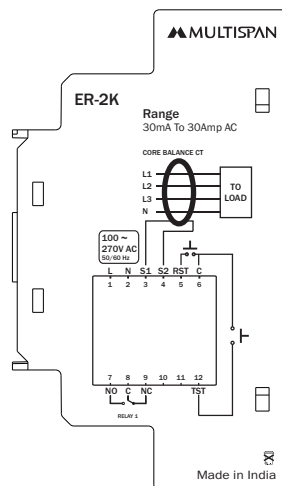

KEY OPERATION

FUNCTION	KEY PRESS
OPERATION MODE	
To Enter in Test Mode	(TST) For 5 sec
To Reset the Relay Contact Manually After Tripping	(RST) For 1 sec

NOTE :

To Configure fault type 'NO' or 'NC'

- 1) Press reset key then power on instrument , Reset key pressed continuously up to 5 Second.
- 2) If front relay indication is 'ON' Means relay is 'NC' in healthy condition.
- 3) One can change by pressing 'TEST' key , If front relay indication is 'OFF' means relay is 'NO' in healthy condition.
- 4) Then Power OFF Instrument save the parameter.

MAINTENANCE

- 1) The equipment should be cleaned regularly to avoid blockage of ventilating parts.
- 2) Clean the equipment with a clean soft cloth. Do not use isopropyl alcohol or any other cleaning agent.
- 3) Fusible resistor must not be replaced by operator.



SAFETY PRECAUTION

All safety related codifications, symbols and instructions that appear in this operating manual or on the equipment must be strictly followed to ensure the safety of the operating personnel as well as the instrument.

If all the equipment is not handled in a manner specified by the manufacturer, it might impair the protection provided by the equipment.



Read complete instructions prior to installation and operation of the unit.



WARNING : Risk of electric shock.

INSTALLATION GUIDELINES

- 1) Do not allow pieces of metal, wire clippings, or fine metallic fillings from installation to enter the product or else it may lead to a safety hazard that may in turn endanger life or cause electrical shock to the operator.
- 2) Circuit breaker or mains switch must be installed between power source and supply terminal to facilitate power 'ON' or 'OFF' function. However this mains switch or circuit breaker must be installed at convenient place normally accessible to the operator.
- 3) Use and store the instrument within the specified ambient temperature and humidity ranges as mentioned in this manual.

MECHANICAL INSTALLATION

- 1) To install the instrument on a DIN rail, raise the clamp at the back of the instrument and place it on the rail. Now release the clamp, so the instrument fits on the DIN rail.
- 2) Ensure proper fitting of the instrument by pulling it outwards.
- 3) To remove the instrument raise the clamp to release it from the DIN rail.
- 4) The equipment in its installed state must not come in close proximity to any heating source, caustic vapors, oil steam, or other unwanted process byproducts.
- 5) Do not connect anything to unused terminals.

WARNING GUIDELINES



WARNING : Risk of electric shock.

- 1) To prevent the risk of electric shock, power supply to the equipment must be kept OFF while doing the wiring arrangement. Do not touch the terminals while power is being supplied.
- 2) To reduce electro magnetic interference, use wire with adequate rating and twists of the same of equal size shall be made with shortest connection.
- 3) Cable used for connection to power source, must have a cross section of 1mm or greater. These wires should have insulations capacity made of at least 1.5kV.
- 4) A better anti-noise effect can be expected by using standard power supply cable for the instrument.

TEST MODE

To Enter In Test Mode

Press (TST) Key for 5 sec

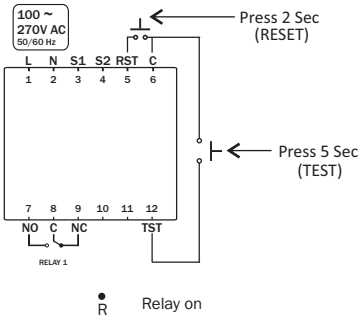

- To exit from test mode, short (RST) Pin for 2 second
OR Press (RST) key for 2 sec.

LED STATUS INDICATION

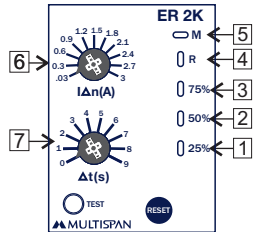

1) 25% LED	
Leakage Current \geq 25%	LED Continuously ON
2) 50% LED	
Leakage Current \geq 50%	LED Continuously ON
3) 75% LED	
Leakage Current \geq 75%	LED Continuously ON
4) Relay LED	
Control Output Indication (ON/OFF)	
5) MAIN LED	
6) $I\Delta n(A)$	
Current Range	
7) $\Delta t(s)$	
Trip Second	

TRIP FUNCTION

Relay Fault mode = ON

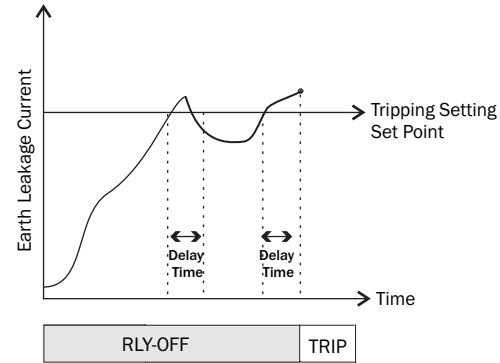

RESET FUNCTION

1) Manual Reset

NOTE: When Leakage Current is below 85% Off set point.