

MULTISPAN

User Manual

EPM-14-M1



Multispans Control Instruments Pvt Ltd

72/B, Phase 1, GIDC Estate, Vatva, Ahmedabad-382445, Gujarat, India.

export@multispansindia.com +91-9978991483

www.multispansindia.com

Technical Specification

Model	EPM-14-M1
Display	UPPER: 7 Seg, 8digit,0.39", RED LED display for KWH LOWER: 7 Seg, 4digit,0.39", GREEN LED display for KW
Size (mm)	96(H) X 96 (W) X 54 (D) mm
Panel Cutout	92 X 92 mm
Voltage Input	50 To 520V AC L-L CAT III 30 To 300V AC L-N
Current Input	50mA To 5Amp AC direct or C.T Selectable up to 6000/5 ratio
Active Power (KW)	0000-9999 KW
Active Energy (KWh)	0-99999999 KWH
Power Supply	100 to 270V AC,50/60Hz,Approx 4VA
Output	Pulse Output : Voltage range 24V DC Max (External) Pulse Width : 10 to 500ms Selectable & With Modbus
Frequency	45 To 65 Hz
Wiring System	3Ph-4W
Protection Level (As per request)	IP-65 (Front side) As per IS/IEC 60529 : 2001
Operating Temperature	0°C To 50°C
Relative Humidity	Up to 95% RH Non Condensing

Page 2

Terminal Diagram

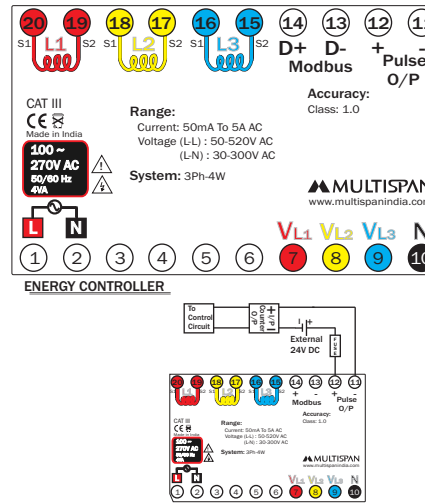

Pulse output from meter can be used alarm generator or total energy controller by interfacing it with pre settable counter and control circuits (Contactors, Relay, trip Circuit). The counter is loaded with the maximum energy consumption. When count is reaches setpoint it provides output to control Circuit to take action.

Page 3

PULSE OUTPUT

It is an optically isolated solid state pulse output which drives the remote counter, PLC, DCS stations etc. It does not require multiplication factor. Pulse output settings (like Energy per Pulse and Pulse on Time) are user programmable in the field.

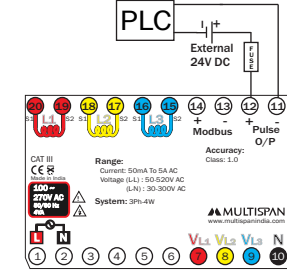

Pulse output from meter can be interfaced into a process through a PLC for on line control of energy content in the process. If the PLC has a self Excited digital input, external DC supply is not needed. The kwh pulse is also used to derive average kwh information at the PLC.

Page 4

Press **RESET** key For 5 Sec

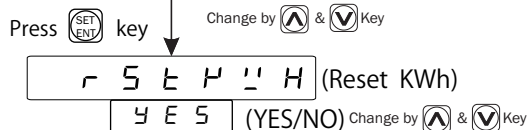
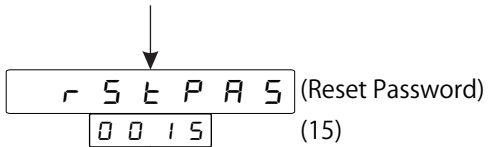

Press **SET/ENT** key

APPLICATION:

- Power Management • Energy Audit
- Control Panels • Plant Maintenance
- Gensets • Quality Control System
- Power Distribution Switchboards
- Building Management System
- Quality Control System

Resolution

CT Primary	Energy Rate Pulse Output
5 to 75	0.01 KWH
76 to 750	0.1 KWH
751 to 7500	1 KWH
7501 to 9999	1 KWH

Page 5

CT PRIMARY SELECTION:

Press **SET/ENT** key For 5 Sec

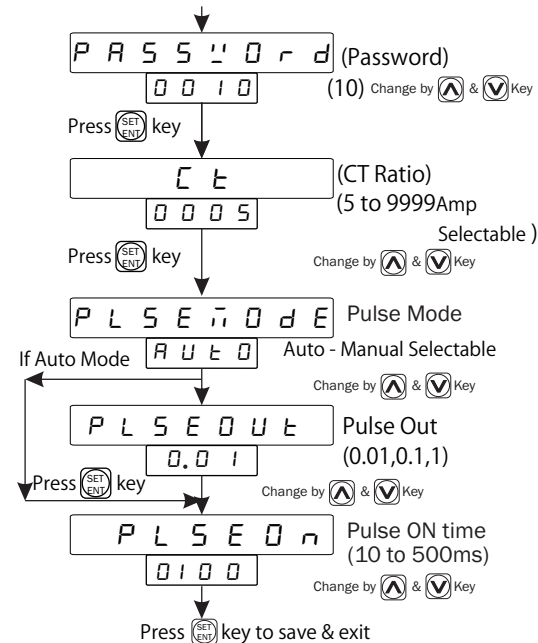

Page 6

To select MODBUS Parameter :

Press **SET/ENT** Key to 5 Second

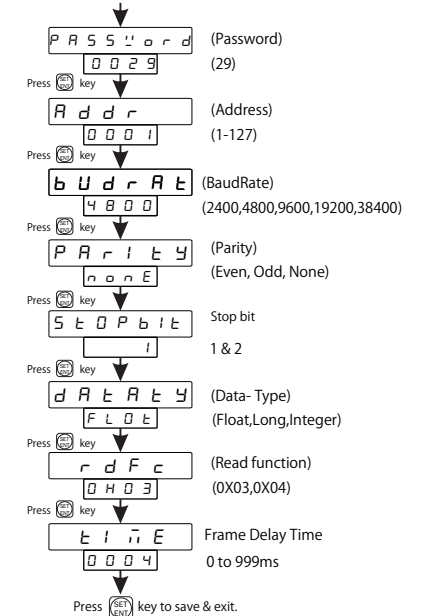

• Range of parameters can be changed by pressing **▲** & **▼** key.

Page 8

Modbus Setting:

- 1). Device Address 1 to 127
- 2). Baudrate 2400, 4800, 9600, 19200, 38400 (bps)
- 3). Parity None, Even, Odd
- 4). Stop bit 1, 2
- 5). Data Type Int, Long, Float
- 6). Read Function Register 0x03 and 0x04
- 7). Frame delay Time 0 to 999ms
- 8). Pulse mode Auto-0, Manual-1

Sr.No	Access Type	Parameter	Register	
			Float	Long
1	R	Kwh	0	0
2	R	NA	NA	NA
3	R	Kw	4	4
4	R	Kwh DP	NA	6
5	R	Kw DP	NA	8
6	R/W	CT Ratio	10	10
7	R/W	Pulse mode : Auto 0 Manual 1	12	12
8	R/W	Energy Rate 0.01 0 0.1 1 1 2 10 3	14	14
9	R/W	Pulse on time	16	16
10	R/W	Address	18	18

Page 9

if datatype is long or integer :

if KWh dp = 1
actual value of KWh = KWh/10

if KW dp = 1
actual value of KW = KW /10

if KWh dp = 2
actual value of KWh = KWh/100

if KW dp = 2
actual value of KW = KW/100

if KWh dp = 3
actual value of KWh = KWh/1000

if KW dp = 3
actual value of KW = KW/1000

Page 13

11	R/W	Baudrate : Selection Value 2400 0 4800 1 9600 2 19200 3 38400 4	20	20
12	R/W	Parity : NONE 0 Even 1 Odd 2	22	22
13	R/W	Stop bit : Stop bit 0 Stop bit 1	24	24
14	R/W	Data type : Integer 0 Long 1 Float 2	26	26
15	R/W	RDFC : 0 x 03 0 0 x 04 1	28	28
16	R/W	Frame delay Time	30	30
17	R/W	Kwh Reset	32	32

Note : To reset energy write 15 value in sr.17 parameter :

Page 10

SAFETY PRECAUTION

All safety related codifications, symbols and instructions that appear in this operating manual or on the equipment must be strictly followed to ensure the safety of the operating personnel as well as the instrument.

If all the equipment is not handled in a manner specified by the manufacturer, it might impair the protection provided by the equipment.



Read complete instructions prior to installation and operation of the unit.



WARNING : Risk of electric shock.

WARNING GUIDELINES



WARNING : Risk of electric shock.

1. To prevent the risk of electric shock, power supply to the equipment must be kept OFF while doing the wiring arrangement. Do not touch the terminals while power is being supplied.
2. To reduce electro magnetic interference, use wire with adequate rating and twists of the same of equal size shall be made with shortest connection.
3. Cable used for connection to power source, must have a cross section of 1mm or greater. These wires should have insulations capacity made of at least 1.5kV.

Page 14

For Integer :

Sr.No	Access Type	Parameter	Register	
			Data Type	Integer :
1	R	Kwh (fist 4 digit)	0	
2	R	Kwh (last 4 digit)	1	
3	R	Kw	2	
4	R	Kwh DP	3	
5	R	Kw DP	4	
6	R/W	CT Ratio	5	
7	R/W	Pulse mode Auto 0 Manual 1	6	
8	R/W	Energy Rate 0.01 0 0.1 1 1 2 10 3	7	
9	R/W	Pulse ON Time	8	
10	R/W	Address	9	

Page 11

11	R/W	Baudrate Selection Value 2400 0 4800 1 9600 2 19200 3 38400 4	10
12	R/W	Parity NONE 0 Even 1 Odd 2	11
13	R/W	Stop Bit Stop bit 0 Stop bit 1	12
14	R/W	Datatype Integer 0 Long 1 Float 2	13
15	R/W	RDFC 0 x 03 0 0 x 04 1	14
16	R/W	Time	15
17	R/W	Kwh Reset	16

Note : To reset energy write 15 value in sr.17 parameter:

Page 12

MECHANICAL INSTALLATION GUIDELINES

1. Prepare the panel cutout with proper dimensions as shown above.
2. Fit the unit into the panel with the help of clamp given.
3. The equipment in its installed state must not come in close proximity to any heating source, caustic vapors, oil steam, or other unwanted process Byproducts.
4. Use the specified size of crimp terminal (M3.5 screws) to wire the terminal block. Tightening the screws on the terminal block using the tightening torque of the range of 1.2 N.m.
5. Do not connect anything to unused terminals.

MAINTENANCE

1. The equipment should be cleaned regularly to avoid blockage of ventilating parts.
2. Clean the equipment with a clean soft cloth. Do not use isopropyl alcohol or any other cleaning agent.
3. Fusible resistor must not be replaced by operator.

Page 15

Page 16