

KZ48

Specifications 1/5

■ Incremental Type (Hollow conical shaft)

- Feature: small, logical compact configuration, optional various output mode and diameter of shaft
- Application: servo motor、 textile industry、 packing machinery、 small instrument , etc , for automation control
- External dimensions: external diameter Ø48mm, thickness 34mm, diameter of hole Ø9mm depth 15mm(taper 1:10)
- Resolution: up to 8192P/R
- Supply voltage: DC5V; DC8-30V
- Protection: IP40
- Cable length: 500mm
- Weight: about 140g

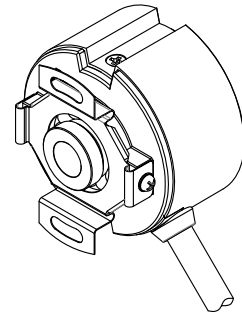

■ Model Guide

- Model form (filled required parameters in the box as following)

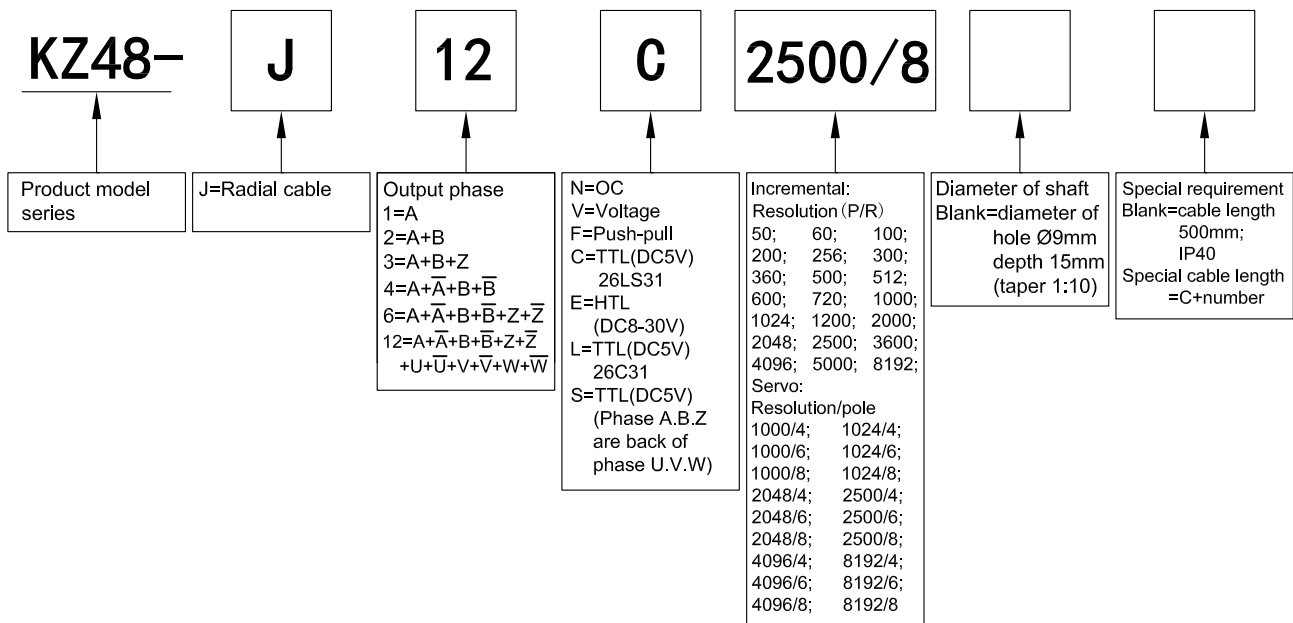

- Must choose supply voltage: DC5V; DC8-30V

KZ48

Specifications 2/5

Output Mode

Output type	Output circuit	Output wave form	Connection
OC		<p> $T(360^\circ)$ $a \quad b \quad c \quad d$ $a.b.c.d = \frac{T}{4} \pm \frac{T}{8}$ Phase A is ahead of B by $\frac{T}{4} \pm \frac{T}{8}$, rotate direction CW (View from shaft end, direction is clockwise rotation) $\frac{T}{4} \pm \frac{T}{8}$ CW direction \rightarrow </p>	0=GND 1=red=DC5V; DC8-30V 2=black=OV 3=white=A 4=green=B 5=yellow=Z
Push-Pull		<p> $T(360^\circ)$ $a \quad b \quad c \quad d$ $a.b.c.d = \frac{T}{4} \pm \frac{T}{8}$ Phase A is ahead of B by $\frac{T}{4} \pm \frac{T}{8}$, rotate direction CW (View from shaft end, direction is clockwise rotation) $\frac{T}{4} \pm \frac{T}{8}$ CW direction \rightarrow </p>	
Voltage		<p> $T(360^\circ)$ $a \quad b \quad c \quad d$ $a.b.c.d = \frac{T}{4} \pm \frac{T}{8}$ Phase A is ahead of B by $\frac{T}{4} \pm \frac{T}{8}$, rotate direction CW (View from shaft end, direction is clockwise rotation) $\frac{T}{4} \pm \frac{T}{8}$ CW direction \rightarrow </p>	
TTL HTL		<p> $T(360^\circ)$ $a \quad b \quad c \quad d$ $a.b.c.d = \frac{T}{4} \pm \frac{T}{8}$ Phase A is ahead of B by $\frac{T}{4} \pm \frac{T}{8}$, rotate direction CW (View from shaft end, direction is clockwise rotation) $\frac{T}{4} \pm \frac{T}{8}$ CW direction \rightarrow </p>	

KZ48

Specifications 3/5

● Output Mode

Output type	Output circuit	Output wave form	Connection																																																																	
TTL		<p> $a, b, c, d = \frac{T}{4} \pm \frac{T}{8}$ $e = T \pm \frac{T}{2}$ f: center of phase Z to rise point of phase U, that is $\pm 0.3^\circ$ </p> <p>CCW direction → (Viewed from shaft end when installing)</p>	0=shielding=GND 1=red=DC5V 2=black=OV 3=white=A 4=green=B 5=yellow=Z 6=white/black= \bar{A} 7=green/black= \bar{B} 8=yellow/black= \bar{Z} 9=blue=U 10=grey=V 11=pink=W 12=blue/black= \bar{U} 13=grey/black= \bar{V} 14=pink/black= \bar{W}																																																																	
TTL (phase A,B,Z are back of phase U,V,W)	<table border="1"> <thead> <tr> <th>pole</th> <th>g,h,j,k,m,n</th> <th>r</th> </tr> </thead> <tbody> <tr> <td>4</td> <td>$30 \pm 1^\circ$</td> <td>180°</td> </tr> <tr> <td>6</td> <td>$20 \pm 1^\circ$</td> <td>120°</td> </tr> <tr> <td>8</td> <td>$15 \pm 1^\circ$</td> <td>90°</td> </tr> </tbody> </table>	pole	g,h,j,k,m,n	r	4	$30 \pm 1^\circ$	180°	6	$20 \pm 1^\circ$	120°	8	$15 \pm 1^\circ$	90°	<p> $a, b, c, d = \frac{T}{4} \pm \frac{T}{8}$ $e = T \pm \frac{T}{2}$ f: center of phase Z to rise point of phase U, that is $\pm 0.3^\circ$ </p> <p>CCW direction → (Viewed from shaft end when installing)</p>	<table border="1"> <thead> <tr> <th rowspan="2">No.</th> <th rowspan="2">Function Color</th> <th colspan="3">Mode</th> </tr> <tr> <th>1</th> <th>2</th> <th>3</th> </tr> </thead> <tbody> <tr> <td>3</td> <td>white</td> <td>HZ</td> <td>U</td> <td>A</td> </tr> <tr> <td>6</td> <td>white/black</td> <td>HZ</td> <td>\bar{U}</td> <td>\bar{A}</td> </tr> <tr> <td>4</td> <td>green</td> <td>HZ</td> <td>V</td> <td>B</td> </tr> <tr> <td>7</td> <td>green/black</td> <td>HZ</td> <td>\bar{V}</td> <td>\bar{B}</td> </tr> <tr> <td>5</td> <td>yellow</td> <td>HZ</td> <td>W</td> <td>Z</td> </tr> <tr> <td>8</td> <td>yellow/black</td> <td>HZ</td> <td>\bar{W}</td> <td>\bar{Z}</td> </tr> <tr> <td>1</td> <td>red</td> <td colspan="3">DC+5V</td> </tr> <tr> <td>2</td> <td>black</td> <td colspan="3">OV</td> </tr> <tr> <td>0</td> <td>shielding</td> <td colspan="3">GND</td> </tr> </tbody> </table>	No.	Function Color	Mode			1	2	3	3	white	HZ	U	A	6	white/black	HZ	\bar{U}	\bar{A}	4	green	HZ	V	B	7	green/black	HZ	\bar{V}	\bar{B}	5	yellow	HZ	W	Z	8	yellow/black	HZ	\bar{W}	\bar{Z}	1	red	DC+5V			2	black	OV			0	shielding	GND		
pole	g,h,j,k,m,n	r																																																																		
4	$30 \pm 1^\circ$	180°																																																																		
6	$20 \pm 1^\circ$	120°																																																																		
8	$15 \pm 1^\circ$	90°																																																																		
No.	Function Color	Mode																																																																		
		1	2	3																																																																
3	white	HZ	U	A																																																																
6	white/black	HZ	\bar{U}	\bar{A}																																																																
4	green	HZ	V	B																																																																
7	green/black	HZ	\bar{V}	\bar{B}																																																																
5	yellow	HZ	W	Z																																																																
8	yellow/black	HZ	\bar{W}	\bar{Z}																																																																
1	red	DC+5V																																																																		
2	black	OV																																																																		
0	shielding	GND																																																																		
<p>Timing Chart</p> <p> Supply voltage: 5 ± 0.25, 4.25 ± 0.3 Power on: 35MIN, 7±2 Instantaneous power down Power off: 35MIN, 7±2 Mode: 1, 2, 3, 1, 2, 3 Time(msec): 510±220, 22±11 </p> <p> Symbol signification ★: indicate position of UVW channel ☆: position to start counting ABZ channel □: non-using zone HZ: high impedance </p>																																																																				

■ Electrical Characteristics

Parameter Item	Output type	OC	Voltage	Push-pull	TTL(26LS31)	TTL(26C31)	TTL(26C31) (Phase A,B,Z are back of phase U,V,W)	HTL(HD7)	
		Supply voltage		DC+5V±5% & DC8V-30V±5%			DC+5V±5%		DC8-30V±5%
Consumption current		100mA Max			120mA Max				
Allowable ripple		≤3%rms							
Top response frequency		100KHz			200KHz		300KHz		
Output volume	Output current	Input	≤30mA	Load resistance 2.2K	≤30mA	≤±20mA		≤±50mA	
		Output	—		≤10mA				
	Output voltage	"H"	—	—	≥[(Supply voltage) -2.5V]	≥2.5V		≥V _{cc} -3 V _{DC}	
		"L"	≤0.4V	≤0.7V(less than 20mA)	≤0.4V(30mA)	≤0.5V		≤ 1V V _{DC}	
Load voltage		≤DC30V	—	—					
Rise & Fall time		Less than 2us(cable length: 2m)			Less than 1us(Cable length: 2m)		≤100ns		
Insulation strength		AC500V 60s							
Insulation resistance		10MΩ							
Mark to space ratio		45% to 55%							
Phase shift between A & B		90°±10° (low speed,frequency ≤1000Hz)							
		90°±20° (high speed,frequency >1000Hz)							
Origin motion		Low level available	High level available	Low level available	—	Low level available	—		
Delay motion time *		—				510±220ms		—	
GND		not connect to encoder							

* Phase A,B,Z are back of phase U,V,W when power on.

■ Mechanical Characteristics

Shaft	∅9mm depth 15mm (taper 1:10)
Starting torque	Less than $9.8 \times 10^{-3} \text{N} \cdot \text{m}$
Inertia moment	Less than $6.5 \times 10^{-6} \text{kg} \cdot \text{m}^2$
Shaft load	Radial 50N; Axial 30N
Slew speed	≤5000 rpm
Bearing Life	1.5×10^9 revs at rated load(100000hrs at 2500RPM)
Shell	Die cast aluminum
Weight	about 140g

■ Environmental Specifications

Environmental temperature	Operating: -20~+85°C(repeatable winding cable: -10°C); Storage: -25~+90°C
Environmental humidity	Operating and storage: 35~85%RH(noncondensing)
Vibration(endure)	Amplitude 0.75mm,5~55Hz,2h for X,Y,Z direction individually
Shock(endure)	490m/s ² 11ms three times for X,Y,Z direction individually
Protection	IP40

KZ48 Specifications 5/5

Basic Dimensions

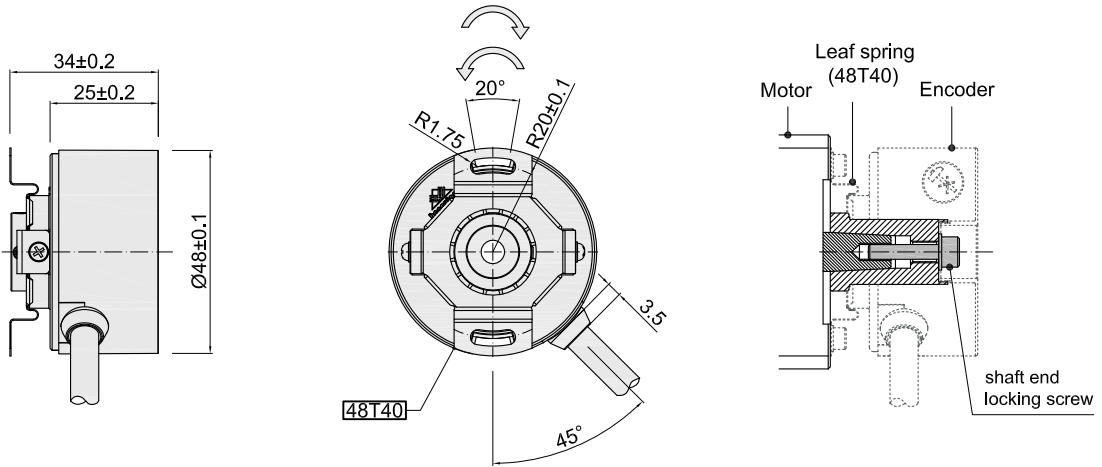

Assembling requirement

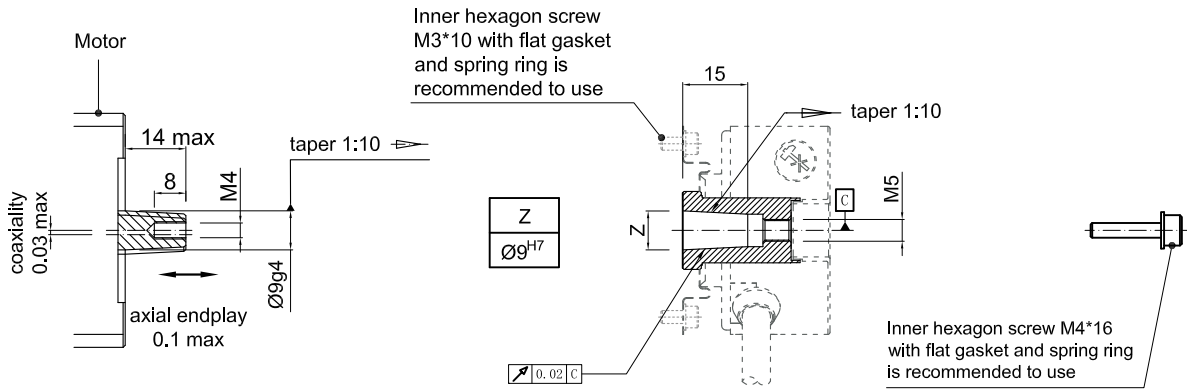

Leaf spring

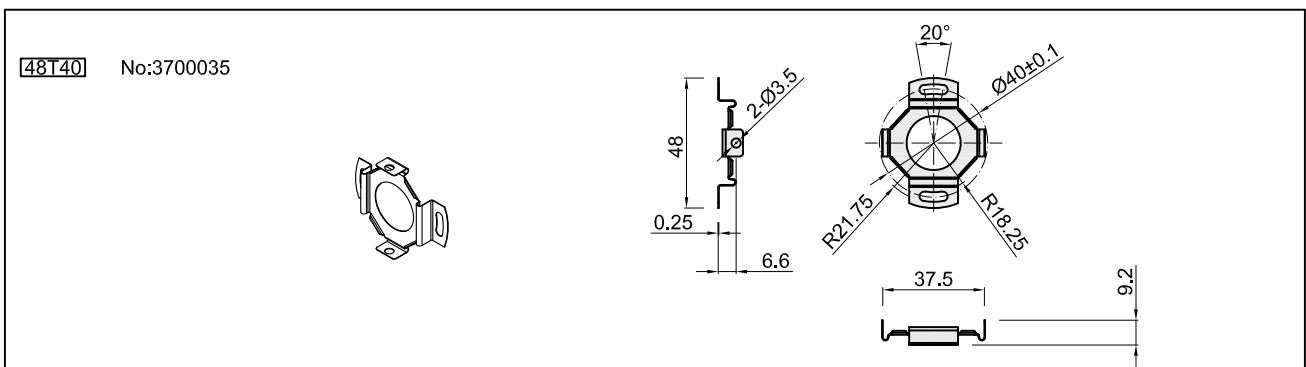

About vibration

Unit: mm

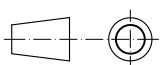

= Rotate direction of incremental signal output shaft

= Rotate direction of servo signal output shaft

Vibration act on encoder always cause wrong pulse , so we should pay attention to working place. More pulse per revolution , narrower groovy spacing of grating , more effect to encoder by vibration, when rev is low or stop , vibration act on shaft or main body would cause grating vibrating , so encoder might make wrong pulse.